

JEE-MAIN EXAMINATION – JANUARY 2025

(HELD ON THURSDAY 23rd JANUARY 2025)

TIME : 3 : 00 PM TO 6 : 00 PM

PHYSICS

TEST PAPER WITH SOLUTION

SECTION-A

26. A ball having kinetic energy KE, is projected at an angle of 60° from the horizontal. What will be the kinetic energy of ball at the highest point of its flight?

- (1) $\frac{(KE)}{8}$ (2) $\frac{(KE)}{4}$
 (3) $\frac{(KE)}{16}$ (4) $\frac{(KE)}{2}$

Ans. (2)

Sol. Initial K.E,

$$K.E. = \frac{1}{2} mu^2$$

Speed at heighest point

$$V = u \cos 60^\circ = \frac{u}{2}$$

$$\therefore KE_2 = \frac{1}{2} m \left(\frac{u}{2} \right)^2$$

$$= \frac{1}{4} \times \frac{1}{2} mu^2$$

$$= \frac{KE}{4}$$

27. Two charges $7 \mu\text{C}$ and $-4 \mu\text{C}$ are placed at $(-7 \text{ cm}, 0, 0)$ and $(7 \text{ cm}, 0, 0)$ respectively. Given, $\epsilon_0 = 8.85 \times 10^{-12} \text{ C}^2 \text{ N}^{-1} \text{ m}^{-2}$, the electrostatic potential energy of the charge configuration is :

- (1) -1.5 J (2) -2.0 J
 (3) -1.2 J (4) -1.8 J

Ans. (4)

Sol. P.E. of two charges

$$u = \frac{1}{4\pi\epsilon_0} \frac{q_1q_2}{r}$$

$$r = \sqrt{(x_2 - x_1)^2 + (y_2 - y_1)^2 + (z_2 - z_1)^2}$$

$$= 14 \text{ cm}$$

$$\therefore u = \frac{9 \times 10^9 \times 7 \times 10^{-6} \times (-4) \times 10^{-6}}{14 \times 10^{-2}}$$

$$= -1.8 \text{ J}$$

28. The refractive index of the material of a glass prism is $\sqrt{3}$. The angle of minimum deviation is equal to the angle of the prism. What is the angle of the prism?

- (1) 50° (2) 60°
 (3) 58° (4) 48°

Ans. (2)

Sol.
$$\mu = \frac{\sin \left(\frac{A + \delta_{\min}}{2} \right)}{\sin \frac{A}{2}}$$

Given $\delta_{\min} = A$

$$\sqrt{3} = \frac{\sin A}{\sin \frac{A}{2}} = \frac{2 \sin \frac{A}{2} \cos \frac{A}{2}}{\sin \frac{A}{2}}$$

$$\cos \frac{A}{2} = \frac{\sqrt{3}}{2}$$

$$A = 60^\circ$$

29. The equation of a transverse wave travelling along a string is $y(x, t) = 4.0 \sin [20 \times 10^{-3} x + 600t]$ mm, where x is in the mm and t is in second. The velocity of the wave is :

- (1) $+30 \text{ m/s}$ (2) -60 m/s
 (3) -30 m/s (4) $+60 \text{ m/s}$

Ans. (3)

Sol. $y = 4 \sin (20 \times 10^{-3} x + 600 t)$

Here $\omega = 600 \text{ s}^{-1}$

$$k = 20 \times 10^{-3} \text{ m/s}^{-1}$$

$$\therefore v = \frac{w}{k} = \frac{600}{20 \times 10^{-3}}$$

$$= 30 \times 10^{-3} \text{ mm/s}$$

$$= 30 \text{ m/s}$$

& direction is towards -ve x axis

$$\therefore v = -30 \text{ m/s}$$

30. The energy of a system is given as $E(t) = \alpha^3 e^{-\beta t}$, where t is the time and $\beta = 0.3 \text{ s}^{-1}$. The errors in the measurement of α and t are 1.2% and 1.6%, respectively. At $t = 5 \text{ s}$, maximum percentage error in the energy is :

- (1) 4% (2) 11.6%
(3) 6% (4) 8.4%

Ans. (3)

Sol. $\alpha^3 e^{-\beta t}$

$$\ln E = 3 \ln \alpha - \beta t$$

$$\left(\frac{dE}{E}\right)_{\max} = \frac{3d\alpha}{\alpha} + \beta \frac{dt}{t} \times t$$

$$= 3 \times 1.2\% + (0.3 \times 1.6 \times 5)\%$$

$$= 6\%$$

31. In photoelectric effect an em-wave is incident on a metal surface and electrons are ejected from the surface. If the work function of the metal is 2.14 eV and stopping potential is 2V, what is the wavelength of the em-wave?

(Given $hc = 1242 \text{ eVnm}$ where h is the Planck's constant and c is the speed of light in vaccum.)

- (1) 400 nm (2) 600 nm
(3) 200 nm (4) 300 nm

Ans. (4)

Sol. $eV_s = E - \phi$

$$2 \text{ eV} = E - 2.14 \text{ eV}$$

$$E = 4.14 \text{ eV}$$

$$E = \frac{hc}{\lambda}$$

$$\lambda = \frac{1242}{4.14} = 300 \text{ nm}$$

32. A circular disk of radius R meter and mass M kg is rotating around the axis perpendicular to the disk. An external torque is applied to the disk such that $\theta(t) = 5t^2 - 8t$, where $\theta(t)$ is the angular position of the rotating disc as a function of time t .

How much power is delivered by the applied torque, when $t = 2\text{s}$?

- (1) 60 MR^2 (2) 72 MR^2
(3) 108 MR^2 (4) 8 MR^2

Ans. (1)

Sol. $\theta = 5t^2 - 8t$

$$\omega = \frac{d\theta}{dt} = 10t - 8$$

$$\alpha = \frac{d\omega}{dt} = 10$$

$$\therefore p = \tau\omega$$

$$= (I\alpha)\omega$$

$$= \left(\frac{mR^2}{2}\right)\alpha\omega$$

$$= \left(\frac{mR^2}{2}\right)(10)(10t - 8)$$

$$\text{Put } t = 2$$

$$p = 60 \text{ mR}^2$$

33. Water flows in a horizontal pipe whose one end is closed with a valve. The reading of the pressure gauge attached to the pipe is P_1 . The reading of the pressure gauge falls to P_2 when the valve is opened. The speed of water flowing in the pipe is proportional to

- (1) $\sqrt{P_1 - P_2}$ (2) $(P_1 - P_2)^2$
(3) $(P_1 - P_2)^4$ (4) $P_1 - P_2$

Ans. (1)

Sol. By Bernoulli equation

$$P_1 + \frac{1}{2} \rho \times 0^2 = P_2 + \frac{1}{2} \rho v^2$$

$$v = \sqrt{2\rho(P_1 - P_2)}$$

34. Match List-I with List-II.

List-I	List-II
(A) Permeability of free space	(I) $[M L^2 T^{-2}]$
(B) Magnetic field	(II) $[M T^{-2} A^{-1}]$
(C) Magnetic moment	(III) $[M L T^{-2} A^{-2}]$
(D) Torsional constant	(IV) $[L^2 A]$

Choose the **correct** answer from the options given below :

- (1) (A)-(I), (B)-(IV), (C)-(II), (D)-(III)
(2) (A)-(II), (B)-(I), (C)-(III), (D)-(IV)
(3) (A)-(IV), (B)-(III), (C)-(I), (D)-(II)
(4) (A)-(III), (B)-(II), (C)-(IV), (D)-(I)

Ans. (4)

Sol. $B = \frac{\mu_0 I}{2\pi r}$

$$\Rightarrow [\mu_0] = \left[\frac{B \times r}{I} \right] = \left[\frac{MT^{-2}A^{-1} \times L}{A} \right] = [MLT^{-2}A^{-2}]$$

magnetic field $F = qvB$

$$B = \left[\frac{MLT^{-2}}{ATL/T} \right] = [MT^{-2}A^{-1}]$$

$$[M] = [NTA] = [M] = [ML^2]$$

$$\tau = c\theta \Rightarrow c = \left[\frac{\tau}{\theta} \right] = [ML^2T^{-2}]$$

35. If a satellite orbiting the Earth is 9 times closer to the Earth than the Moon, what is the time period of rotation of the satellite? Given rotational time period of Moon = 27 days and gravitational attraction between the satellite and the moon is neglected.

- (1) 1 day (2) 81 days
(3) 27 days (4) 3 days

Ans. (1)

Sol. $T^2 \propto R^3$

$$\left(\frac{T_m}{T_s} \right)^2 = \left(\frac{R}{R/9} \right)^3$$

$$\frac{T_m}{T_s} = (3)^3$$

$$\Rightarrow T_s = \left(\frac{27}{27} \right) = 1 \text{ day}$$

36. Two point charges $-4 \mu\text{C}$ and $4 \mu\text{C}$, constituting an electric dipole, are placed at $(-9, 0, 0)$ cm and $(9, 0, 0)$ cm in a uniform electric field of strength 10^4 NC^{-1} . The work done on the dipole in rotating it from the equilibrium through 180° is :

- (1) 14.4 mJ (2) 18.4 mJ
(3) 12.4 mJ (4) 16.4 mJ

Ans. (1)

Sol. $U = -PE \cos \theta$

$$w_{\text{ext}} = \Delta U = U_f - U_i = -PE \cos 180^\circ + PE \cos 0^\circ$$

$$w_{\text{ext}} = 2PE$$

$$= 2 \times (4 \times 10^{-6}) (18) \times 10^4$$

$$= 144 \times 10^{-2}$$

$$= 14.4 \text{ mJ}$$

37. A galvanometer having a coil of resistance 30Ω need 20 mA of current for full-scale deflection. If a maximum current of 3 A is to be measured using this galvanometer, the resistance of the shunt to be added to the galvanometer should be $\frac{30}{X} \Omega$, where

X is

- (1) 447 (2) 298
(3) 149 (4) 596

Ans. (3)

Sol.

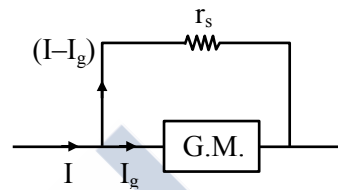

$$I_g R_g = (I - I_g) r_s$$

$$20 \times 10^{-3} \times 30 = (3 - 0.02) \times r_s$$

$$r_s = \left(\frac{0.6}{2.98} \right) = \frac{30}{x}$$

$$x = \left(\frac{2.98 \times 30}{0.6} \right) = 149$$

38. The width of one of the two slits in Young's double slit experiment is d while that of the other slit is xd . If the ratio of the maximum to the minimum intensity in the interference pattern on the screen is $9 : 4$ then what is the value of x ?

(Assume that the field strength varies according to the slit width.)

- (1) 2 (2) 3
(3) 5 (4) 4

Ans. (3)

Sol. $I \propto (\text{width})^2$

$$\left(\frac{\sqrt{I_1} + \sqrt{I_2}}{\sqrt{I_1} - \sqrt{I_2}} \right)^2 = \frac{9}{4}$$

$$\frac{\sqrt{I_1} + \sqrt{I_2}}{\sqrt{I_1} - \sqrt{I_2}} = \frac{3}{2}$$

$$\frac{(x+1)d}{(x-1)d} = \frac{3}{2}$$

$$\Rightarrow 3x - 3 = 2x + 2$$

$$x = 5$$

39. Given below are two statements. One is labelled as **Assertion (A)** and the other is labelled as **Reason (R)**.

Assertion (A) : The binding energy per nucleon is found to be practically independent of the atomic number A , for nuclei with mass numbers between 30 and 170.

Reason (R) : Nuclear force is long range.

In the light of the above statements, choose the **correct** answer from the options given below :

- (1) (A) is false but (R) is true
- (2) (A) is true but (R) is false
- (3) Both (A) and (R) are true and (R) is the correct explanation of (A)
- (4) Both (A) and (R) are true but (R) is NOT the correct explanation of (A)

Ans. (2)

Sol. Conceptual

40. Water of mass m gram is slowly heated to increase the temperature from T_1 to T_2 . The change in entropy of the water, given specific heat of water is $1 \text{ J kg}^{-1}\text{K}^{-1}$, is :

- (1) zero
- (2) $m(T_2 - T_1)$
- (3) $m \ln\left(\frac{T_1}{T_2}\right)$
- (4) $m \ln\left(\frac{T_2}{T_1}\right)$

Ans. (4)

Sol. $dQ = msdT$

$$dS = \frac{dQ}{T} = \frac{msdT}{T}$$

$$\Delta S = \int \frac{msdT}{T} = ms \ln \frac{T_f}{T_i}$$

$$\Delta S = m \ln \frac{T_2}{T_1}$$

41. What is the current through the battery in the circuit shown below?

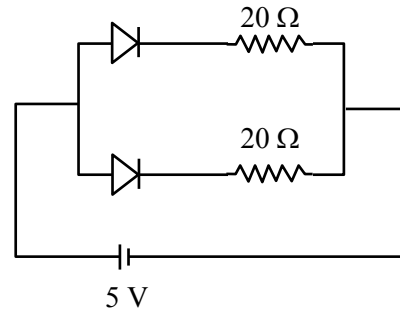

- (1) 1.0 A
- (2) 1.5 A
- (3) 0.5 A
- (4) 0.25 A

Ans. (3)

Sol. Both are forward biased

hence $R_{eq} = 10 \Omega$

$$i = \frac{V}{R} = \frac{5}{10} = \frac{1}{2} \text{ A}$$

42. A plane electromagnetic wave of frequency 20 MHz travels in free space along the $+x$ direction. At a particular point in space and time, the electric field vector of the wave is $E_y = 9.3 \text{ Vm}^{-1}$. Then, the magnetic field vector of the wave at that point is-

- (1) $B_z = 9.3 \times 10^{-8} \text{ T}$
- (2) $B_z = 1.55 \times 10^{-8} \text{ T}$
- (3) $B_z = 6.2 \times 10^{-8} \text{ T}$
- (4) $B_z = 3.1 \times 10^{-8} \text{ T}$

Ans. (4)

Sol. $E = BC$

$$9.3 = B \times 3 \times 10^8$$

$$B = \frac{9.3}{3 \times 10^8} = 3.1 \times 10^{-8} \text{ T}$$

43.

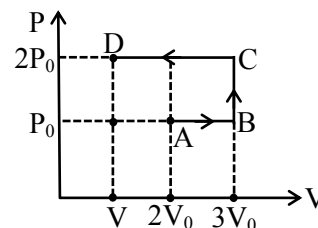

Using the given P-V diagram, the work done by an ideal gas along the path ABCD is-

- (1) $4 P_0 V_0$
- (2) $3 P_0 V_0$
- (3) $-4 P_0 V_0$
- (4) $-3 P_0 V_0$

Ans. (4)

Sol. $W_{ABCD} = W_{AB} + W_{BC} + W_{CD}$
 $= P_0V_0 + 0 + (-2P_0 \times 2V_0)$
 $= P_0V_0 - 4P_0V_0$
 $= -3P_0V_0$

44. A concave mirror of focal length f in air is dipped in a liquid of refractive index μ . Its focal length in the liquid will be :

- (1) $\frac{f}{\mu}$ (2) $\frac{f}{(\mu-1)}$
 (3) μf (4) f

Ans. (4)

Sol. Focal length of mirror will not change because focal length of mirror doesn't depend on medium.

45. A massless spring gets elongated by amount x_1 under a tension of 5N. Its elongation is x_2 under the tension of 7N. For the elongation of $(5x_1 - 2x_2)$, the tension in the spring will be,

- (1) 15 N (2) 20 N
 (3) 11 N (4) 39 N

Ans. (3)

Sol. $kx_1 = 5N$
 $kx_2 = 7N$
 $k(5x_1 - 2x_2) = 5kx_1 - 2kx_2$
 $= 5 \times 5 - 2 \times 7 = 11 N$

SECTION-B

46. An air bubble of radius 1.0 mm is observed at a depth of 20 cm below the free surface of a liquid having surface tension 0.095 J/m² and density 10³ kg/m³. The difference between pressure inside the bubble and atmospheric pressure _____ N/m². (Take $g = 10 \text{ m/s}^2$)

Ans. (2190)

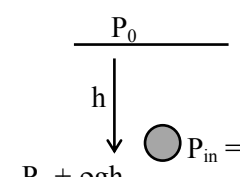
Sol. 
 $P_{in} = P_0 + \rho gh + \frac{2T}{R}$
 $\Delta P = P_{in} - P_0$

$$= \rho gh + \frac{2T}{R} = \frac{1000 \times 10 \times 20}{100} + \frac{2 \times 0.095}{10^{-3}}$$

$$= 2000 + 190$$

$$= 2190$$

47. A satellite of mass $\frac{M}{2}$ is revolving around earth in a circular orbit at a height of $\frac{R}{3}$ from earth surface. The angular momentum of the satellite is $M\sqrt{\frac{GMR}{x}}$. The value of x is _____, where M and R are the mass and radius of earth, respectively. (G is the gravitational constant)

Ans. (3)

Sol. (i) If earth is assumed to be stationary

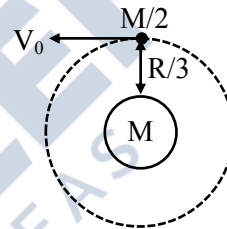

orbital velocity $v_0 = \sqrt{\frac{GM}{4R/3}} = \sqrt{\frac{3GM}{4R}}$

Angular momentum of satellite = $\frac{M}{2} v_0 \frac{4R}{3}$

$$= \frac{M}{2} \cdot \sqrt{\frac{3GM}{4R}} \cdot \frac{4R}{3}$$

$$= M\sqrt{\frac{GMR}{3}}$$

$$x = 3$$

(ii) Since mass of satellite is comparable to the mass of earth.

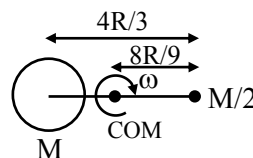

$$\frac{G.M.\frac{M}{2}}{\left(\frac{4R}{3}\right)^2} = \frac{M}{2} \omega^2 \cdot \frac{8R}{9}$$

$$\omega = \sqrt{\frac{81GM}{128R^3}}$$

Angular momentum of satellite about common centre of mass,

$$L = \frac{M}{2} \cdot \left(\frac{8R}{9}\right)^2 \cdot \omega$$

$$L = M \sqrt{GMR \left(\frac{8}{81}\right)}$$

$$x = \frac{81}{8} \approx 10$$

48. At steady state the charge on the capacitor, as shown in the circuit below, is _____ μC .

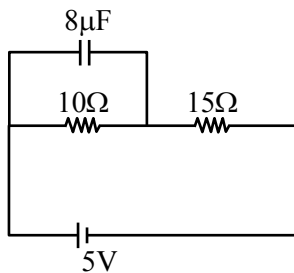

Ans. (16)

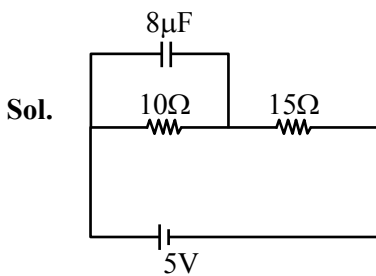

$$i = \left(\frac{5}{25}\right)$$

$$Q = CV$$

$$Q = (8 \times 10^{-6}) \left(\frac{5}{25} \times 10\right)$$

$$Q = \left(\frac{8 \times 5 \times 10^{-2}}{25}\right) = 16 \mu\text{C}$$

49. A time varying potential difference is applied between the plates of a parallel plate capacitor of capacitance $2.5 \mu\text{F}$. The dielectric constant of the medium between the capacitor plates is 1. It produces an instantaneous displacement current of 0.25 mA in the intervening space between the capacitor plates, the magnitude of the rate of change of the potential difference will be _____ Vs^{-1} .

Ans. (100)

$$\text{Sol. } \frac{CdV}{dt} = I_d$$

$$\frac{dV}{dt} = \frac{I_d}{C}$$

$$= \frac{0.25 \times 10^{-3}}{2.5 \times 10^{-6}}$$

$$= 100$$

50. In a series LCR circuit, a resistor of 300Ω , a capacitor of 25 nF and an inductor of 100 mH are used. For maximum current in the circuit, the angular frequency of the ac source is _____ $\times 10^4$ radians s^{-1} .

Ans. (2)

$$\text{Sol. } \omega = \frac{1}{\sqrt{LC}}$$

$$\omega = \frac{1}{\sqrt{25 \times 10^{-9} \times 100 \times 10^{-3}}}$$

$$\omega = \frac{10^6}{5 \times 10} = 2$$